

Thank you for purchasing the Valore Wireless Headset (BTS18).

Sleek and comfortable, you can now enjoy up to 13 hours of high quality music wirelessly on the go.

**Important:** Please read the user manual thoroughly before using your wireless headset.

## Specifications:

- Wireless range: 10m
- Battery type: 230mAh Li-polymer battery
- Standby time: Up to 120 hours
- Charging time: Up to 1.5 hours
- Playback time: Up to 13 hours
- Power input: DC5V/300mAh
- Micro USB cable length: 300m
- Cable length: 300mm
- Dimension (L x W x H): 45 x 50 x 35mm
- Material: ABS
- Weight: 25g

## Package Contents:

- Wireless headset
- Micro USB charging cable
- Size S and L ear tips

## UNDERSTANDING THE PRODUCT

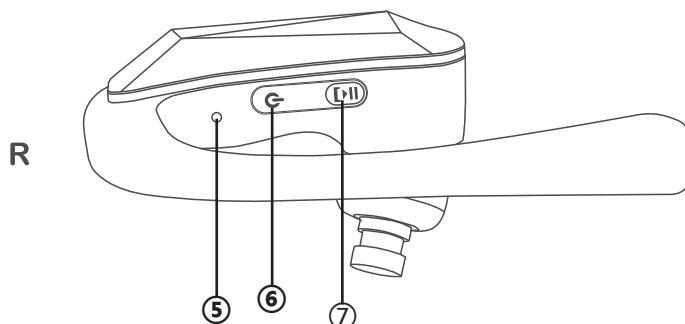
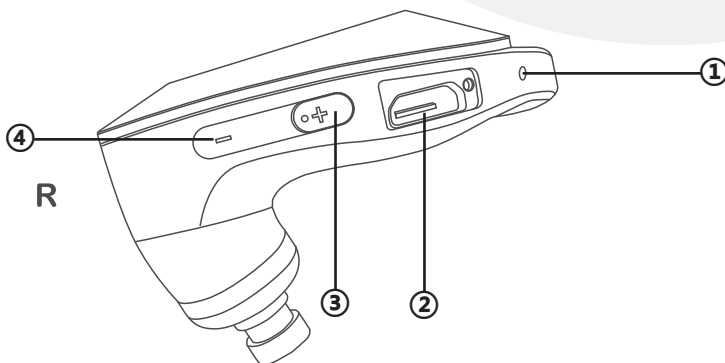

- ① Mic
- ② Micro USB port
- ③ Volume '+'
- ④ Volume '-'
- ⑤ LED indicator
- ⑥ On/Off button
- ⑦ Multi-functional button (M)

# START USING THE WIRELESS HEADSET

## 1) Charging the wireless headset

Connect the USB charging cable to the headset located on the side of the right earpiece.

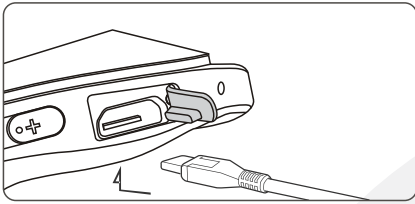

Note: Please charge the headset for at least 8 hours before first use. Please make sure that the headset is switched off when charging is in progress.

COLOR	STATUS	INDICATE
Red	Blinking	Low battery
Red	Solid	Charging
Blue	Solid	Charging complete
Blue and Red	Altering Blinks	Pairing
Blue	Blink every 5 seconds	Connected successfully

## 2) Pairing the wireless headset (switched off)

Step 1: Activate Bluetooth function on your mobile device to begin pairing with headset.

Step 2: Press and hold onto the On/Off button located on the right earpiece until the LED light flickers red and blue.

Step 3: Connect to the headset by selecting 'Valore BTS18' under the device list.

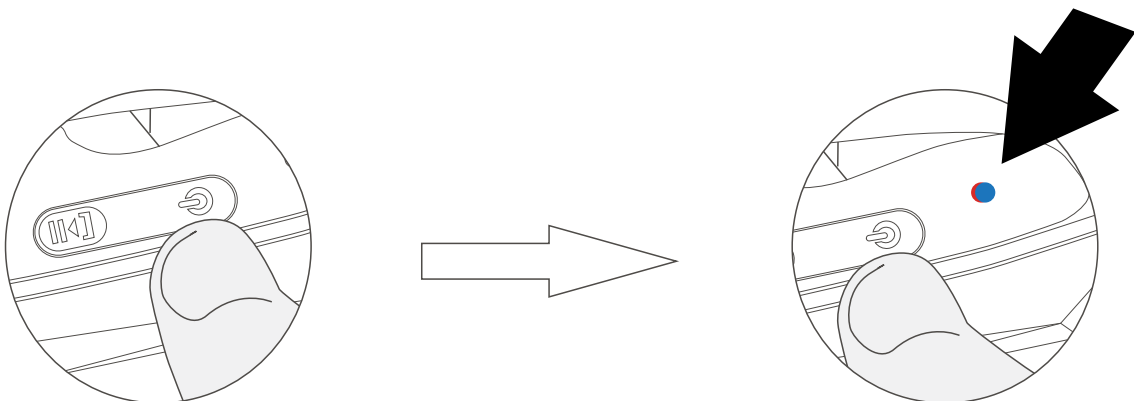

Step 4: Once connected, the LED light at the Bluetooth button will blink blue in interval of 5 seconds.







Note: If the pairing is not successful, please turn off wireless headset first, and then re-pair again. After pairing is successful, paired devices will remember each other. Unless pairing information is deleted because of new pairing, no need to pair when using the next time.

If you want to pair the wireless headset with other devices, please turn off Bluetooth function of existing source device, and pair the wireless headset with the new device according to steps 1-4 mentioned above.

### 3) Wireless headset controls

Summary of Basic Functions		
Function	Action	Signal/Prompt
Power on	Hold the Power button for 6 seconds	Violet light stay for 1 second; Audio
Power-off (Manually)	Hold the Power button for 6 seconds	Violet light stay for 1 second; Audio
Power-off (Automatically)	Stand by for 5 minutes/ Battery voltage below 3.0 V	
Pairing	Hold the Power button for 6 seconds 	Altering Blue & Red Blinks; Audio
	Hold the Multifunction button for 6 seconds 	
Connected		Single blue light blinks every 5 seconds/audio
Reconnect (Manual)	Quick press Multifunction Button 	

Music Playing		
Function	Action	Signal/Prompt
Play / Pause	Press the “M” button 	Audio
Previous / Next	Hold “-”/“+” for 2 seconds	Audio
Volume up/down	Press the “+” / “-” button	Volume(max/min)

Phone Call Function		
Function	Action	Signal/Prompt
Answer / End	Press Multifunction button 	Audio
Reject	Hold Multifunction button for 2 seconds 	Audio
Redial	Quickly double press the “M” button 	Audio
Earphone/Phone Switch	During phone call, hold Multifunction button for 2 seconds	Audio
Volume up/down	Press the “+”/“-” button	Volume(Max/Min)

# TROUBLESHOOTING

## **Issue 1: headset is unable to connect successfully to your mobile device**

Problem 1: Headset's battery is flat

Solution: Fully charge the headset (2.5 hours) and retry connection with your mobile device.

Problem 2: Headset not paired to your mobile device

Solution: Make sure that the headset is successfully paired upon selecting 'Valore BTS-28' in the device list.

Problem 3: Headset and mobile device too far apart

Solution: Make sure that the headset is within a metre range during pairing and connection.

Problem 4: Headset is connected to other mobile device

Solution: Make sure that the headset has already been disconnected before making a new connection with a new device.

## **Issue 2: Sound from the headset is too soft or silent**

Problem 1: Headset's battery is low / flat

Solution: Fully charge the headset (2.5 hours) and retry connection with your mobile device.

Problem 2: Headset or mobile device's volume is too low

Solution: Turn the volume of the headset or mobile device up to increase the volume.

Problem 3: Music track may not be audible

Solution: Make sure that the music track is of a playable format for the mobile device.

Problem 4: Headset and mobile device might not be connected properly.

Solution: Repeat the connection step via Bluetooth/auxiliary cable again to make sure that it is connected properly and try again.

## TECHNICAL SUPPORT & WARRANTY

- For Technical Support, email us at [v.info@valore.sg](mailto:v.info@valore.sg).
- For Warranty Registration, visit [www.valore.sg](http://www.valore.sg).

### Cautions:

Read all the instructions and warnings carefully prior to using this product.

- Do not store the headset in a high temperature environment.
- Do not place the headset near a fire or other excessively hot environments.
- Do not expose this headset to moisture or submerge it in liquid. Keep headset dry at all times.
- Do not attempt to charge the headset using any other method or connection other than the headset's provided charging cable.
- Do not disassemble this headset or attempt to repair or modify it in any manner.
- Be cautious of excessive drops, bumps, abrasions or other impacts to this headset. If there is any damage to the headset such as dents, punctures, tears, deformities or corrosion, stop using the headset and contact us immediately via email at [v.info@valore.sg](mailto:v.info@valore.sg), or return this product to the store where you have purchased it from.
- If the product produces an abnormal smell, high temperature (low temperature during normal use), discolours or changes shape abnormally, stop using the product and contact us immediately via email at [v.info@valore.sg](mailto:v.info@valore.sg).

### DISCLAIMER & TRADEMARKS

All information, trademarks, logos, graphics, and images ("Materials") provided on this user manual are copyrighted or trademarked and are the property of Valore Lifestyle Pte Ltd. Any unauthorized use of any material contained on the instruction manual may violate copyright laws, trademark laws, laws of privacy and communications statutes.

The trademarks, service marks and logos used and displayed in the Materials are registered and unregistered trademarks and service marks of Valore and others. All other registered and unregistered company names, product names and marks mentioned herein the ("Materials") are the property of their respective owners and may be trademarks or registered trademarks.

Complies with  
IDA standards  
DA 103331



Inspired by Valore Singapore

For full range of Valore products visit [www.valore.sg](http://www.valore.sg)