

Thank you for purchasing the Valore Smart Watch (VHA-17).

- Displays time, steps, calories, distance & heart rate
- Resting & exercise heart rate tracking
- Move reminder
- Incoming call & text notifications
- Silent vibrating alarm
- Music & selfie control
- Find My Phone & Find My Smart Watch functions

Important: Please read the user manual thoroughly before using your Smart Watch.

Note: The data collected on the fitness tracker is not for medical usage.

Specifications:

- Battery type: 180mAh lithium battery
- Standby time: Up to 10 days
- Charging time: Approximately 2 hours
- Support: iOS 9.0 / Android 5.0
- Display screen size: 1.3"

Package Contents:

- Smart watch
- Light purple strap
- Charging cable

UNDERSTANDING THE PRODUCT

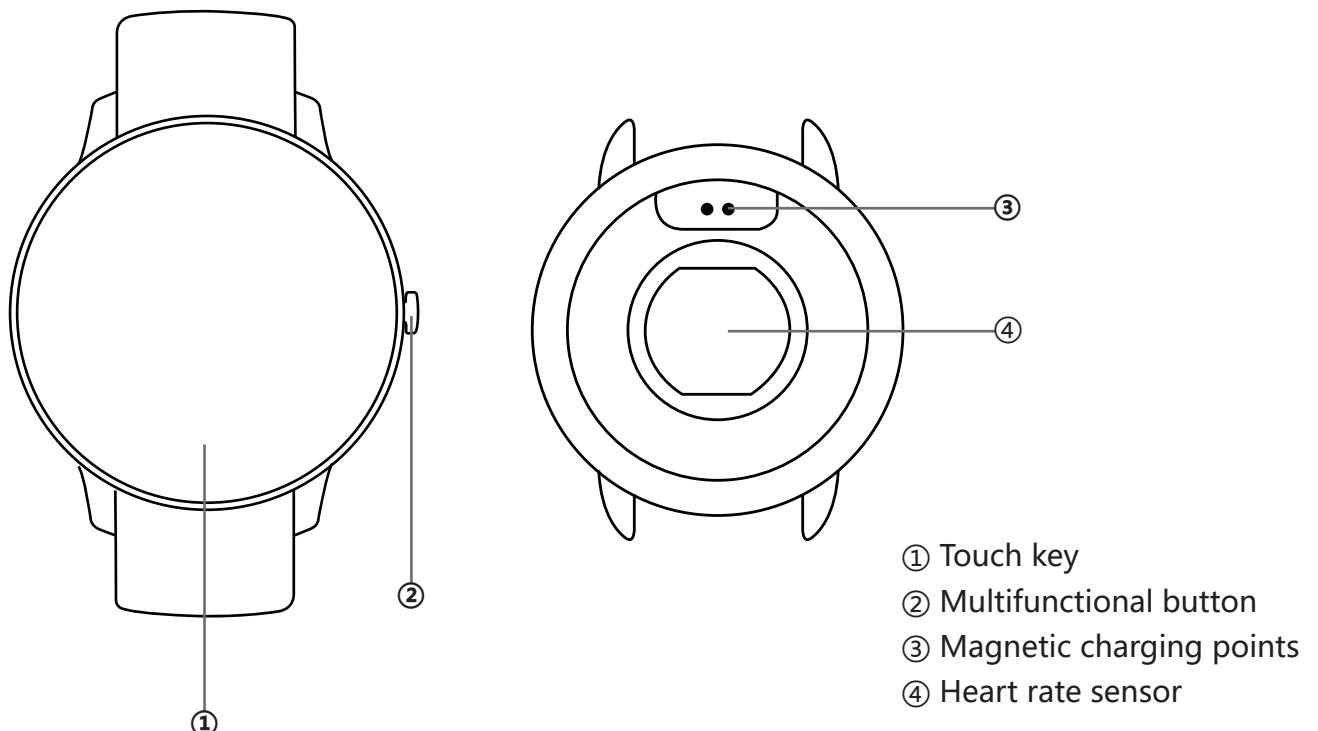

START USING THE SMART WATCH

1) Charging the smart watch

Align pin from charger to charging point located at the back correctly.



2) Power On/Off

Power On: Long press the Multifunctional button to turn the device on.

Power Off: Short press, toggle to “More” function. Long press Touch key to enter, toggle to “Power Off”. Long press Touch key to select.



Long press touch key on this interface

3) How to toggle between interface

Short press the bottom of the screen to move between screens.

Long press the bottom of the screen to enter the selected menu and start measurements.

4) Pairing the Smart Watch

Download the CT FIT app on the App store for iOS device and on the Google Play Store for Android devices.



Scan to download
application

- Before connecting, fully charge the smart watch and switch mobile device's Bluetooth on.
- Launch application and go to the connect icon located at the top right corner.
- Select “Valore VHA-17” to pair.
- To unpair the tracker, click forget device from selection list.

5) Switching watch face

At "Home screen" long press the Touch key to switch watch face.



6) Activity

From "Home screen", short press to see display of daily steps, distance and calories burn.

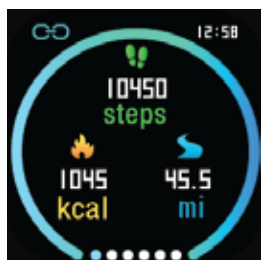

7) Heart rate

Short press again to heart rate screen. The dash will start flashing to indicate calculation.

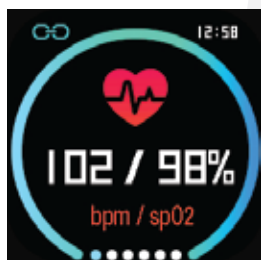

8) Blood pressure

Short press again to blood pressure screen. The dash will start flashing to indicate calculation.



9) Sleep tracking

Short press again to sleep tracking screen. This shows your sleep & deep sleep hours.



10) Training mode

Short press again to training mode screen. Long press the touch key to enter or exit training mode. After entering mode, short press to select amongst different sports.

Long press the touch key to start recording your activity data. These data will be saved to your application after pairing.

11) Relax mode

Short press again to relax mode screen. Long press the touch key to enter or exit relax mode. Use this mode to help control your breathing.

12) Message mode

Short press again to message mode. Long press the screen to enter and view messages. Short press touch key to switch between messages. Only the 5 latest will be displayed. Long press the Multifunctional button to delete all messages.

13) More mode

Short press again to more mode. In this mode includes:



- About
- On/Off heart rate
- Stopwatch
- Find my phone
- Adjust time
- Brightness
- Do not disturb
- Power off

TECHNICAL SUPPORT & WARRANTY

- For Technical Support, email us at v.info@valore.sg.
- For Warranty Registration, visit www.valore.sg.

Cautions:

Read all the instructions and warnings carefully prior to using this product.

- Do not attempt to replace battery or open the enclosure or disassemble this product. Doing so will void the warranty and can result in safety hazard.
- Do not store the fitness tracker in a high temperature environment.
- Do not place the fitness tracker near a fire or other excessively hot environments.
- Do not expose this fitness tracker to moisture or submerge it in liquid. Keep fitness tracker dry at all times.
- Do not disassemble this fitness tracker or attempt to repair or modify it in any manner.
- Be cautious of excessive drops, bumps, abrasions or other impacts to this fitness tracker. If there is any damage to the fitness tracker such as dents, punctures, tears, deformities or corrosion, stop using the fitness tracker and contact us immediately via email at v.info@valore.sg, or return this product to the store where you have purchased it from.
- If the product produces an abnormal smell, high temperature (low temperature during normal use), discolours or changes shape abnormally, stop using the product and contact us immediately via email at v.info@valore.sg.

DISCLAIMER & TRADEMARKS

All information, trademarks, logos, graphics, and images (“Materials”) provided on this user manual are copyrighted or trademarked and are the property of Challenger Technologies Limited. Any unauthorized use of any material contained on the instruction manual may violate copyright laws, trademark laws, laws of privacy and communications statutes.

The trademarks, service marks and logos used and displayed in the Materials are registered and unregistered trademarks and service marks of Valore and others. All other registered and unregistered company names, product names and marks mentioned herein the (“Materials”) are the property of their respective owners and may be trademarks or registered trademarks.

Complies with
IMDA Standards
DA103331



IOS is a trademark or registered trademark of Cisco in the U.S. and other countries and is used under license.

Inspired by Valore Singapore

For full range of Valore products visit www.valore.sg